

# C/E22 N - C/E32 N



C/E22 N



**Sistema Enterprise**

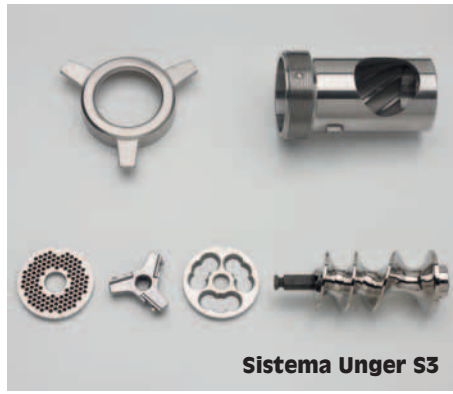

**Sistema Unger S3**

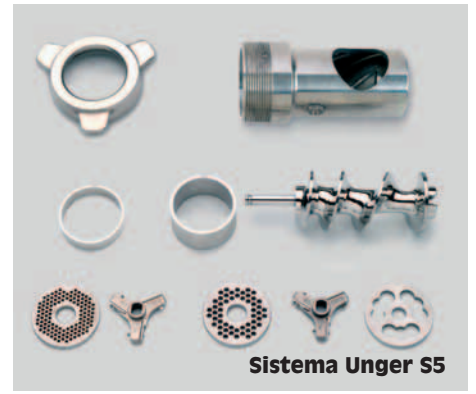

**Sistema Unger S5**



# C/E22 N - C/E32 N

**TRITACARNE DA BANCO 22-32 IN ACCIAIO INOX.** Per medie e alte produzioni. Macchine robuste, affidabili, compatte, facili da pulire. Per macellerie, supermercati, laboratori carni, ristorazione, ...

- Costruzione compatta ed elegante in acciaio inox AISI 304
- Tramoggia estraibile inox AISI 304
- Bocca in acciaio inox AISI 304, facilmente smontabile per la pulizia:

**Enterprise:** 1 piastra ed 1 coltello in acciaio inox, autoaffilanti  
**Unger:** 3 pezzi (Ø 82 mm) e 5 pezzi (Ø 98 mm)

- Pulsanti di marcia e arresto a 24V, sistema NVR.
- Dispositivo di inversione marcia
- Pulizia semplice e veloce
- Macchina conforme alle norme CE in materia di igiene e sicurezza e alle norme specifiche per i tritacarne

**A richiesta**

- Voltaggi speciali, 60Hz

**STAINLESS STEEL TABLE TOP MEAT MINCER 22-32.** For medium and large production; rugged, reliable, compact, easy to clean. Machines suitable for butcher shops, supermarkets, meat processing centres, catering industry,...

- Styled and compact construction in stainless steel AISI 304
- AISI 304 stainless steel removable feed pan
- AISI 304 stainless steel head, readily disassembled for easy cleaning:

**Enterprise:** 1 self sharpening plate and 1 stainless steel knife  
**Unger:** model 22 is available in 3 piece and 5 piece versions (Ø 82 mm) model 32 is available in a 5 piece version (Ø 98 mm)

- Start and stop push button at 24V, NVR system.
- Reverse device
- Easy and fast cleaning
- The machine has been designed in compliance with the CE norms on hygiene and safety and with specific requirement for mincing machines

**On request**

- Special voltages, 60Hz

**HACHOIR A VIANDE EN ACIER INOX 22-32 DU COMPTOIR.** Pour moyennes et hautes productions. Machines robustes, fiables, compactes, supermarchés, centres de transformation des viandes, restauration,...

- Construction solide et de forme élégante en acier inox AISI 304
- Trémie amovible en acier inox AISI 304
- Bouche en acier inox AISI 304 démontable rapidement pour faciliter le nettoyage:

**Enterprise:** 1 plaque et 1 couteau en acier inox autoaffutants  
**Unger:** à 3 pièces et à 5 pièces pour le model 22 (Ø 82 mm) et à 5 pièces pour le model 32 (Ø 98 mm)

- Marche avant et arrêt à 24V - NVR système
- Dispositif d'inversion de marche
- Nettoyage simple et rapide
- Machine conforme aux normes CE en matière d'hygiène et de sécurité, et aux normes spécifiques concernano les hachoirs

**Sur demande**

- Tension particulières, 60Hz

**FLEISCHWOLF AUS ROSTFREIEM STAHL 22-32 TISCHMODELL.** Für mittlere bis hohe Produktionen; robuste, zuverlässige, kompakte und leicht zu reinigen Maschinen. Für Metzgereien, Supermärkte, Fleisch verarbeitende Betriebe, Gastgewerbe,...

- Formschöne und kompakte Konstruktion aus rostfreiem Stahl AISI 304
- Ausziehbarer Trichter aus inox Stahl AISI 304
- Schneckengehäuse aus Rostfreiem Stahl AISI 304, die leicht abnehmbar für die Reinigung ist:

**Enterprise:** 1 Lochschelbe und 1 selbstschärfendes Edelstahlmesser  
**Unger:** 3 teilig (Ø 82 mm) und 5 teilig (Ø 98 mm)

- Volwärtsgang. Stoppaste mit 24V, NVR System.
- Rückwärtsvorrichtung
- Einfache und schnelle Reinigung
- Maschine mit den CE Normen betreffend Hygiene und Sicherheit, sowie den spezifischen Normen für Fleischwölfe konform

**Auf Anfrage**

- Sonderspannungen, 60Hz

**PICADORA DE CARNE EN ACERO INOX 22-32.** Para medianas y altas producciones; máquinas robustas, fiables, compactas, fáciles a limpiar. Para carnicerías, supermercados, laboratorios carnes, hostelería, ...

- Costrucción en acero inox AISI 304 elegante y solida
- Tolva extraíble de acero inox AISI 304
- Boca: de acero inox AISI 304:

**Enterprise:** 1 placa y 1 cuchillo de acero inoxidable autofiladores  
**Unger:** de 3 piezas y 5 piezas el 22 (Ø 82 mm) y de 5 piezas el 32 (Ø 98 mm)

- Marcha avante y parade con 24V, sistema NVR.
- Marcha atras
- Limpieza simple y rapida
- Maquina conforme a las normas CE, en materia de higiene y seguridad y a las normas específicas para las maquinas de picar carne

**Bajo pedido**

- Voltajes especiales, 60Hz

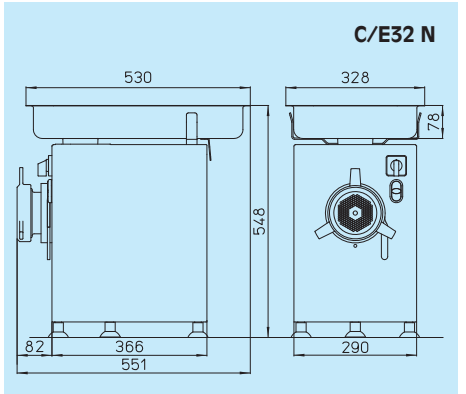
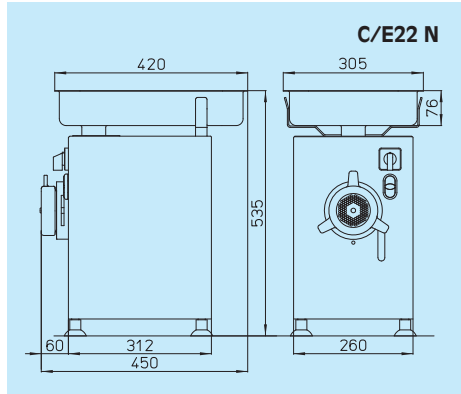

	C/E22 N	C/E32 N
Bocca - Head - Bouche - Gehäuse - Boca	22/82	32/98
Produzione oraria - Hourly output - Production horarje - Stundenleistung - Producción horaria	kg 300	500
Motore trifase - Threephase motor - Moteur triphase - Dreiphasig Motor - Motor trifásico	kW (HP) 1.1 (1.5)	2.2 (3)
Motore monofase - Singlephase motor - Moteur monophasé - Einphasig Motor - Motor monofásico	kW (HP) 1.1 (1.5)	2.2 (3)
Peso netto TF(MF) - Net weight TPH(SPH) - Poids net TPH(MN) - Nettogewicht DPH(EPH) - Peso Neto TF(MF)	kg 32 (33)	44 (50)



**Minerva Omega group s.r.l.**  
 via del Vetraio, 36 z.l. Roveri 2 - 40138 Bologna - Italy  
 tel. +39 051 530.174 - fax +39 051 535.327  
 laminerva@laminerva.it - www.laminerva.it  
 info@omegafoodtech.it - www.omegafoodtech.it  
 UNI EN ISO 9001:2008 - REG. N. 2714



I DATI DEL PRESENTE CATALOGO NON SONO IMPEDIMENTIVI E POTRANNO SUBIRE VARIAZIONI SENZA PREAVVISO. SPECIFICATIONS AND OTHER FEATURES ARE SUBJECT TO CHANGE WITHOUT NOTICE.